



KLT

# THE FUNCTIONAL TIPPING TRAILER



**Anssems** BACKWARDS TIPPING TRAILERS **KLT**

LOW LOADER TRAILERS



FLATBED TRAILERS



MULTIPURPOSE TRAILERS



CAR TRANSPORTERS



**TIPPING TRAILERS**



HARD TOP COVER TRAILERS



BOX VAN TRAILERS



HORSE TRAILERS



WELFARE TRAILERS



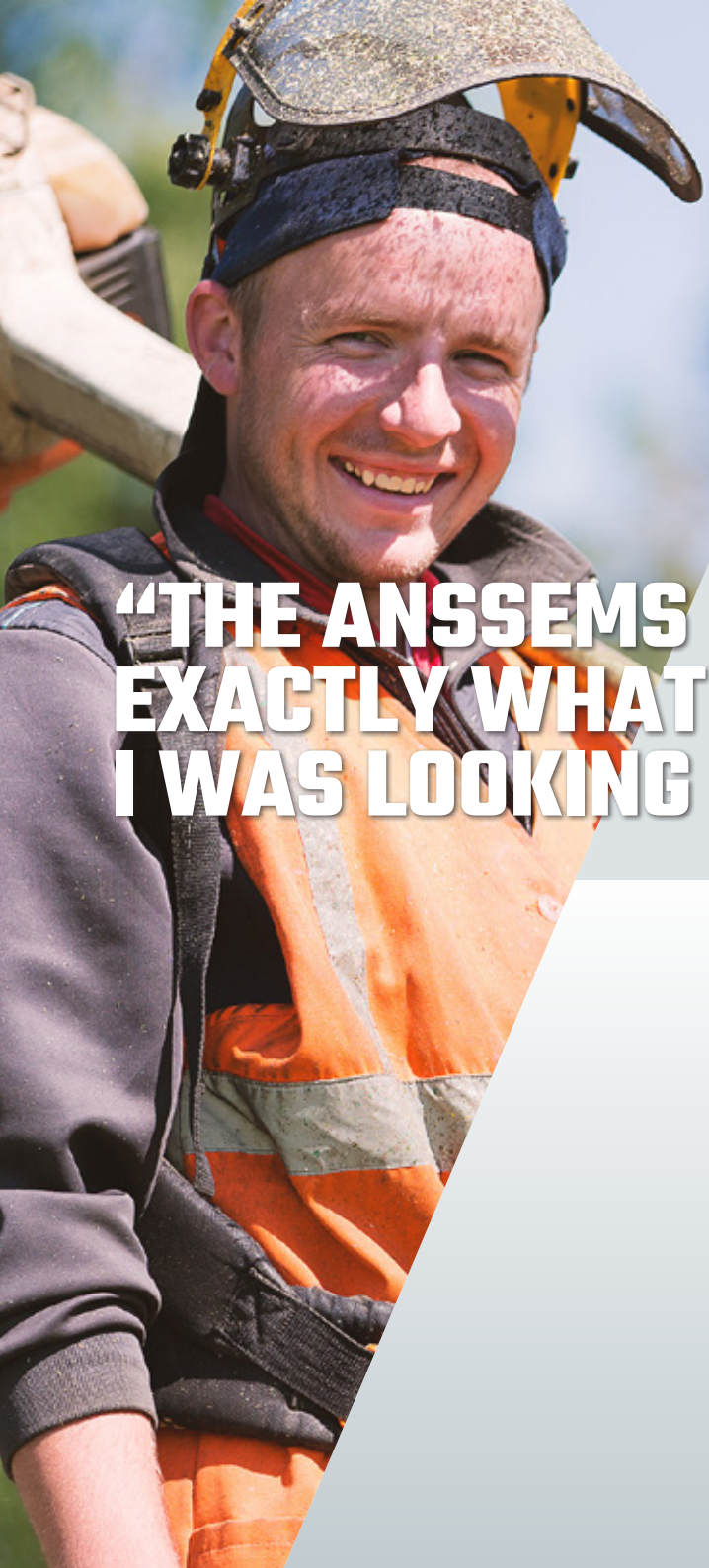

**“THE ANSSEMS KLT IS EXACTLY WHAT I WAS LOOKING FOR”**

## KLT tipping trailers, a reliable workhorse

These budget-friendly, backwards tipping trailers benefit from a low unladen weight meaning they can be used for many applications. The tipping function is operated manually from the A-frame position. The wheel position under the loading floor gives the Anssems KLT a large load area which is easily accessible with the side- and rear panel lowered. All KLT models come as standard with multiple tie down points to help keep your load secure.



KLT single axle braked  
with hydraulic hand pump



KLT tandem braked  
with hydraulic hand pump

## Durable and low weight

The manufacture of the KTL chassis is extremely accurate, using state-of-the-art CNC laser-cut and robot-welded profiles. All parts of the chassis are fully galvanised. The strong loading floor is made of high-grip waterproof plywood, supported by heavy-duty galvanised steel cross-members. Thanks to its smart design, the KTL range maintains maximum load capacity.



A-frame tubes extend to the rear



Reliable and clear lightings



Easily accessible loading floor



Sides easy to open and close



Hydraulic tipping system



Tie rail for movable net- and tie hooks



8 Tie hooks on the edge of the loading floor

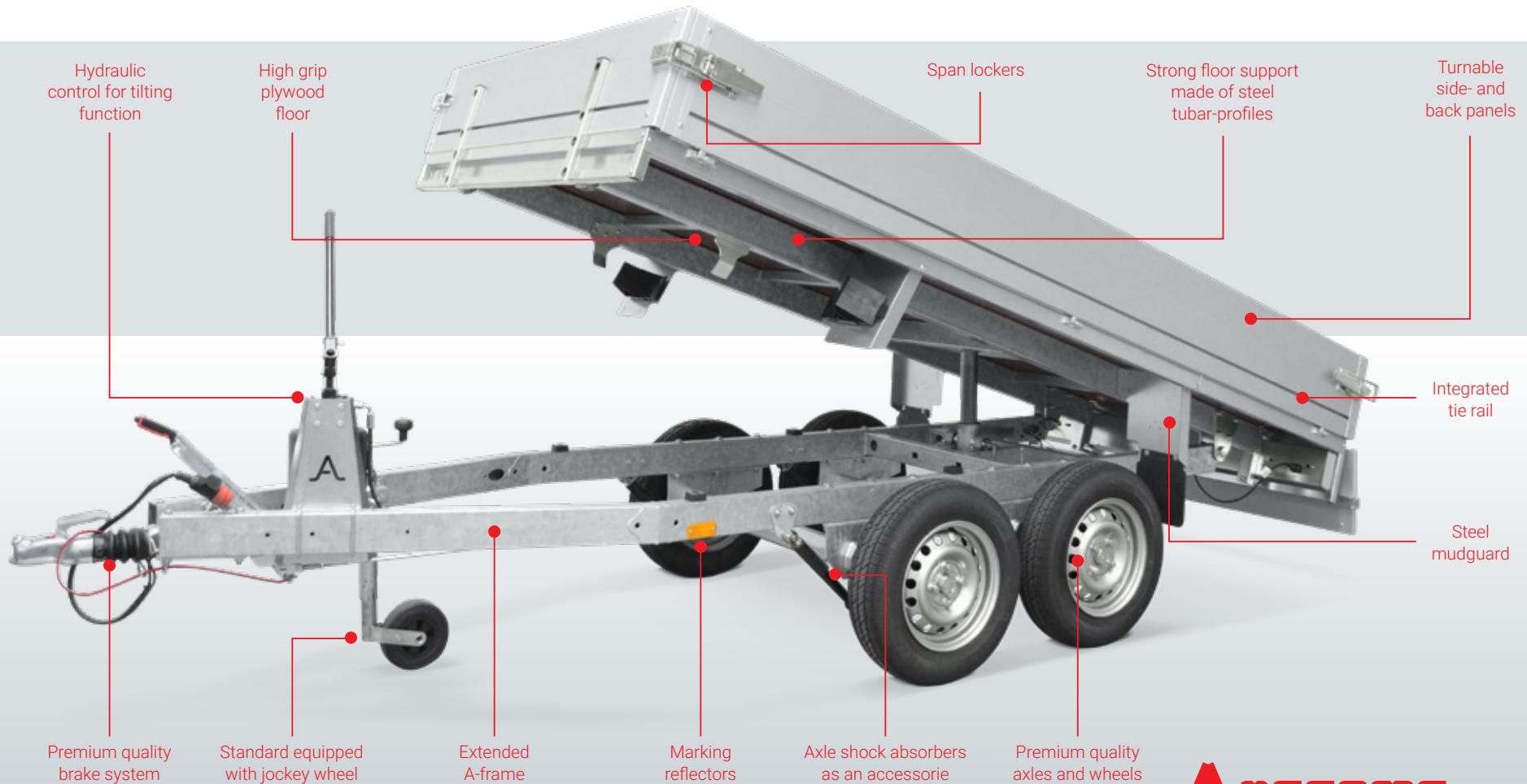

Hydraulic control for tilting function

High grip plywood floor

Span lockers

Strong floor support made of steel tubar-profiles

Turnable side- and back panels

Integrated tie rail

Steel mudguard

Premium quality brake system

Standard equipped with jockey wheel

Extended A-frame

Marking reflectors

Axle shock absorbers as an accessorie

Premium quality axles and wheels

## Multiple possibilities

The KLT backwards-tipping trailers offer great performance, and you can increase their performance and usability by mounting the KLT accessories. Ansems offer plenty of optional extras within the KLT range, allowing you to create a tipper that meets all your requirements.

**“THE EXTENDED PANELS ARE MY NUMBER ONE ACCESSORIES”**



The ladder rack is the number one KLT accessory, offering more mounting options and increasing load protection.



The 30cm extension sides create a total loading height of no less than 60cm. The flat cover is easy to assemble, even when combined with the extension sides.



Accessorie:  
axle shock absorbers for  
extra driving comfort



Accessorie:  
spare wheel



Accessorie:  
spare wheel support



Accessorie:  
net hooks



Accessorie:  
steel ladder rack



Accessorie:  
flat cover

Extended panels  
(height 30 cm)



## Comfort and manoeuvrability

The user-friendly towing properties and reliable braking and lighting system guarantee safe and simple operation. Thanks to its compact size and straightforward operation, the KLT trailer makes light work of transporting bulk goods, such as building materials, logs, or garden waste, to site.

**Anssems**



Type	KLTB 1350 251x150	KLTT 1350 305x150	KLTT 2000 305x150
<b>Gross capacity</b>	1350 kg	1350 kg	2000 kg
<b>Unladen weight (ULW)</b>	300 kg	360 kg	380 kg
<b>Load capacity</b>	1050 kg	990 kg	1620 kg
<b>Axles pcs</b>	1	2	2
<b>Braked version</b>	✓	✓	✓
<b>Tilt function</b>	backwards	backwards	backwards
<b>Hydraulic tilt control</b>	manual	manual	manual
<b>Wheel / tyresize</b>	185/70R13	145/80R13	155/80R13
<b>Rims</b>	steel	steel	steel
<b>Floor type</b>	plywood	plywood	plywood
Internal length (A)	251 cm	305 cm	305 cm
Internal width (B)	150 cm	150 cm	150 cm
Floor height (C)	68 cm	66 cm	67 cm
A-Frame length (D)	105 cm	105 cm	105 cm
Total length (E)	365 cm	419 cm	419 cm
Total width (F)	159 cm	159 cm	159 cm
Total height (G)	98 cm	96 cm	97 cm
Side panel height (H)	30 cm	30 cm	30 cm

Accessoires	KLTB 1350 251x150	KLTT 1350 305x150	KLTT 2000 305x150
Flat cover	✓	✓	✓
Extension sides (H 30 cm)	✓	✓	✓
Ladder rack (H 75 cm)	✓	✓	✓
Tie hooks	✓	✓	✓
Universal aluminium ramps 150 cm	✓	✓	✓
Universal aluminium ramps 200 cm	✓	✓	✓
Universal aluminium ramps 250 cm	✓	✓	✓
Spare wheel with support	✓	✓	✓
Axle shock absorbers	✓	✓	✓

# Low maintenance, high performance

All Anssems KLT models are equipped with premium quality axles, braking system and lighting. In combination with the high quality finish this ensures years of trouble free service.

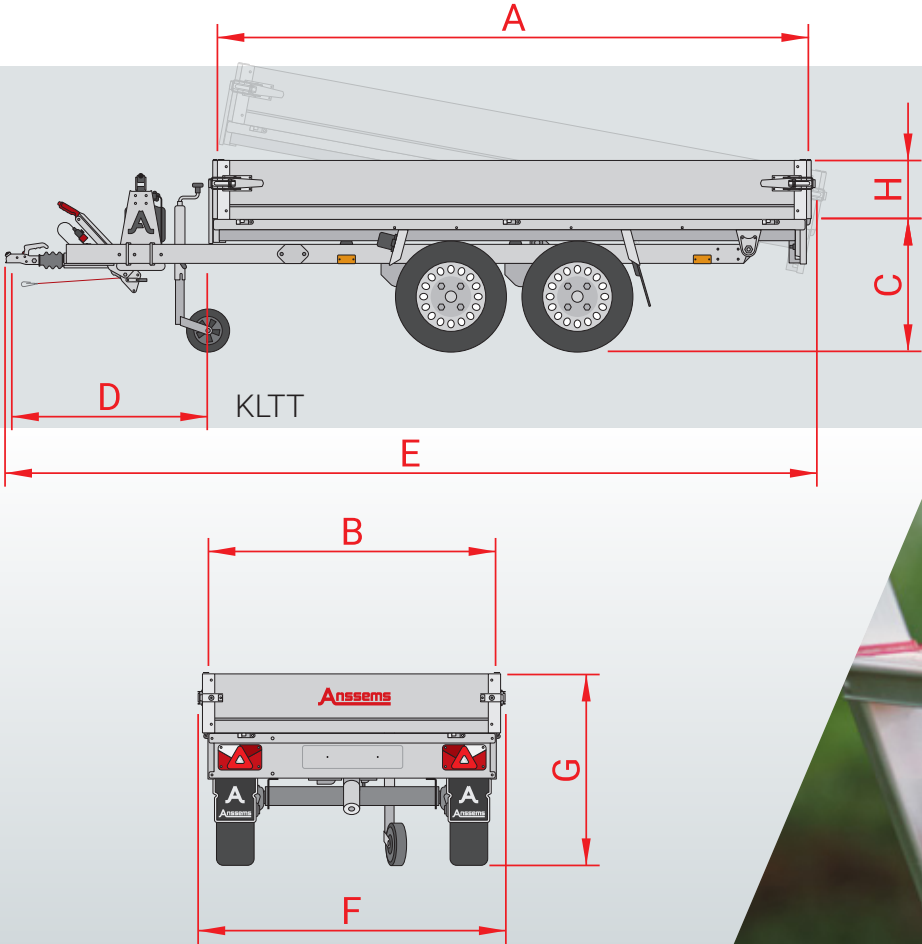

**“MY ANSSEMS KLT SAVES ME TIME DURING TRANSPORT”**



**Anssems**

# Anssems

## Always behind you.

Anssems offers a complete range of transport solutions of flawless quality, and has been doing so since 1977. Our standard, richly equipped trailers are perfect for professional and private users. Our modern machinery is extremely accurate and ensures a consistent high-quality output. Our team checks the result to guarantee a perfect finish. We produce to the highest standards, with user comfort and safety being our top priority. Anssems, when things gets tough, we're right behind you.

Visit: [www.anssems.eu](http://www.anssems.eu)



Your Anssems dealer

AB2302EN-KLT



**A** Low loader trailers **BSX**



**A** Low loader trailers **GT-O**



**A** Low loader trailers **GT-R**



**A** Flatbed trailers **ASX**  
(Incl. ramps)



**A** Flatbed trailers **PSX**



**H** Flatbed trailers **MEDAX**



**A** Flatbed trailers **PLT**



**H** Multipurpose trailers  
**CARAX**



**A** Multipurpose trailers  
**MSX-Basic / MSX**



**A** Car transporters  
**AMT**



**A** Car transporters  
**AMT-ECO**



**A** 3-way tipping trailers  
**KSX**



**A** Backwards tipping trailers  
**KLT**



**A** Hard top cover trailers  
**GT-HT / GT-VT1**



**A** Box van trailers  
**GT-VT2 / GT-VT3 / GT-VT4**



**H** Plant trailers  
**TERRAX**



**H** Plant trailers  
**TERRAX-Basic**



**A** Horse trailers **PTH**



**A** Welfare trailers **PTS**



Anssems Go-Getter

### The Anssems group

**Anssems Aanhangwagens B.V.**  
Ericssonstraat 50  
NL-5121 ML Rijen

**Anssems Anhänger GmbH**  
Londoner Straße 15  
D-48455 Bad Bentheim-Gildehaus

**Anssems Remorques Sarl**  
Rue Pierre Brosolette  
FR-58600 Garchizy

**Hulco Trailers GmbH**  
Wiener Straße 34  
D-48455 Bad Bentheim-Gildehaus